



**FALCON
RIGS**



SR-650

POWER FLOW SPECS

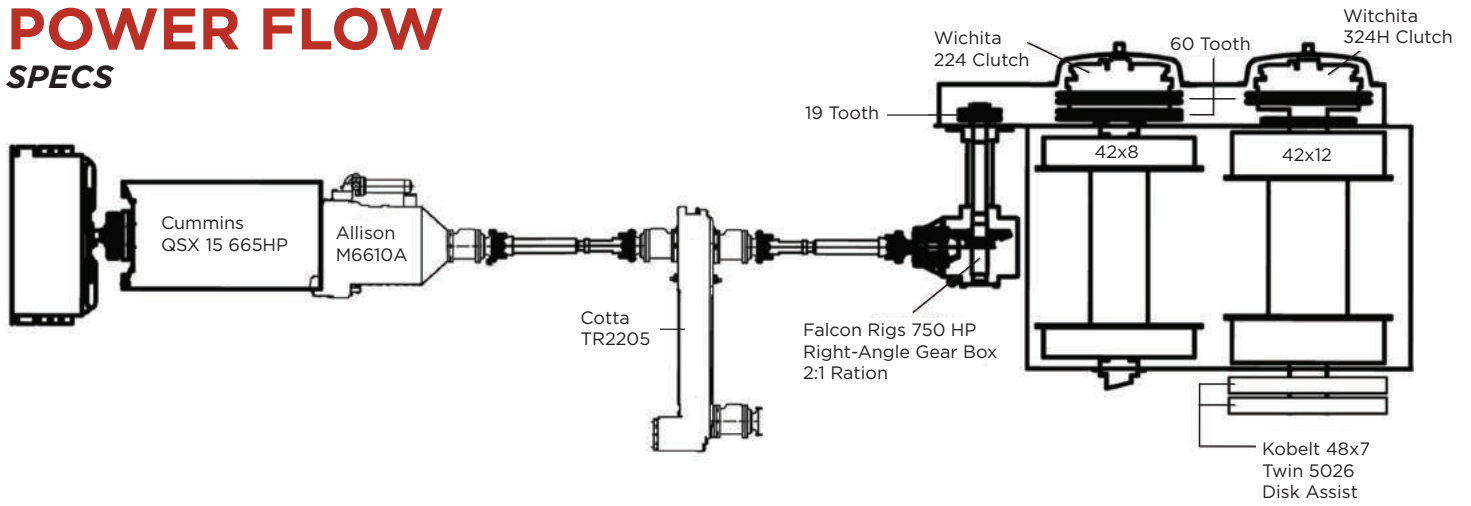

RIG DIAGRAM

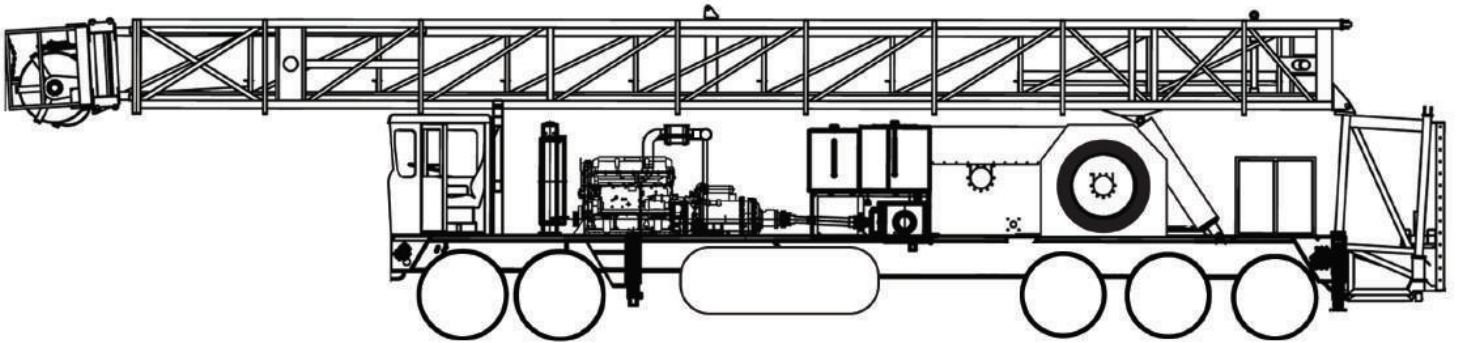



**FALCON
RIGS**



SR-650

Draw Works Model 650/42x12, 42x8

Main Drum

Hardened overlaid demountable water circulated steel brake rims are 42in diameter x 12in wide. Drum shaft diameter is 6.5in. 1 1/8in wire line size standard.

Sand Line Drum

Hardened overlaid demountable steel brake rims are 42in diameter x 8in wide. Wire line capacity is 16,500ft of 9/16.

Draw Works Features

- Water splash brake cooling on sand drum
- Twin Kobelt 5026 48x7 disc assist brake
- 1 1/8in Lebus grooving on main drum
- 224 Wichita Clutch on sand line drum
- 324-H Wichita Clutch on main drum

Mast Model 104/300

(Double Tubing, Triple Rods)-(per API 4F)

- 4-leg fixed base
- Clear height is 104ft below crown
- Static hook load capacity on 6 lines 270,000lbs
*8 lines 300,000lbs
- 36in fast line sheave
- 30in dead line sheave
- 24in sheave cluster
- All sheaves mounted on Timken double row bearings
- Racking platform capacity is 24,000ft of 2 7/8in tubing
- Hydraulic rams for raising and telescoping
- Adjustable work platform

OPTIONS

- Mast lighting
- Standpipes
- Optional Mast Models
 - 108/300

Drive Train

- Standard Cummins QSX15 665hp (Caterpillar or Detroit Diesel optional)
- Allison M6610A 6-speed transmission
- Optional engine cover for weather protection

Carrier

- Standard 5-axle carrier
- Front axles (rated at 22,000lbs each) have spring suspension
- Rear axles (rated at 52,000lbs combined) have walking beam suspension
- Third (non-driving) rear axle with air bag lift suspension rated at 20,000lbs
- All axles monitored by a Bendix Anti-Lock Brake System

OPTIONS

- Fourth (non-driving) rear axle with air bag lift suspension rated at 20,000lbs
- Hydraulically raised operator's station

Controls and Hydraulic System

- Controls for all leveling jacks, mast raising and scoping cylinder, engine, transmission, main drum clutch, winch, and road to winch shifting are located in a stainless steel, clearly marked with laser etching, control box for quick, easy rig-up.
- 50gpm hydraulic pump for all rig hydraulics and tong operation
- Filters provided on suction and return lines
- Standard Braden PD12 Service Winch

Rig Options

- Hydraulic oil cooler for continuous use and hot climate applications
- Cold weather engine package with fuel, oil and coolant heaters
- Ventilated engine/transmission enclosure with removable doors
- Folding walkways on off-operator side
- Rotary drive package