



**FALCON
RIGS**



SR-550

POWER FLOW SPECS

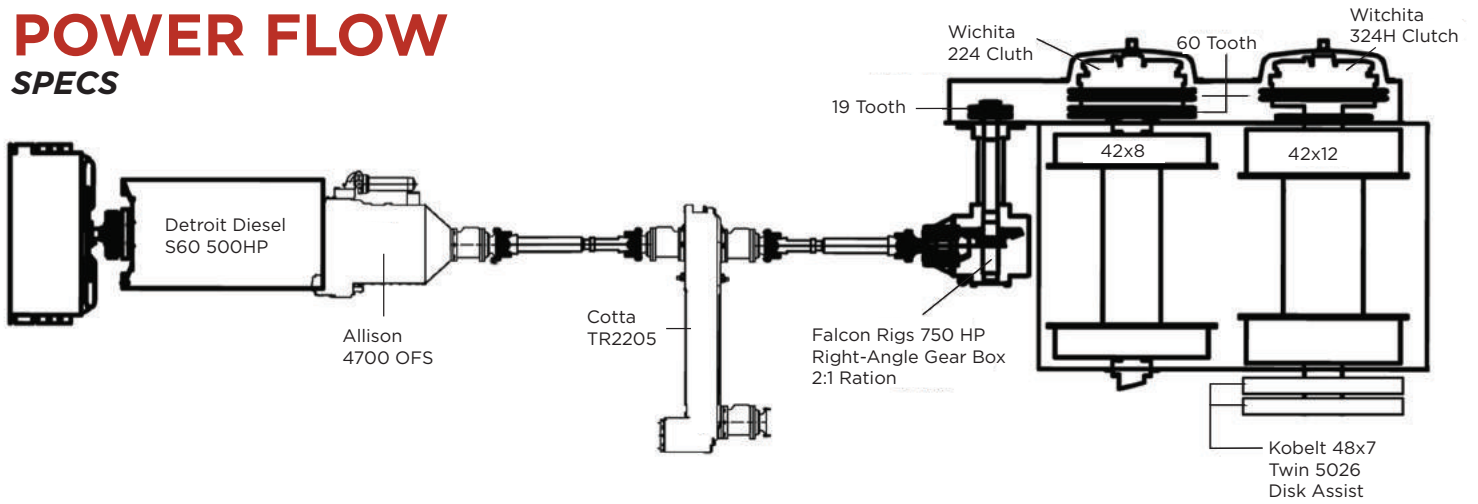

RIG DIAGRAM

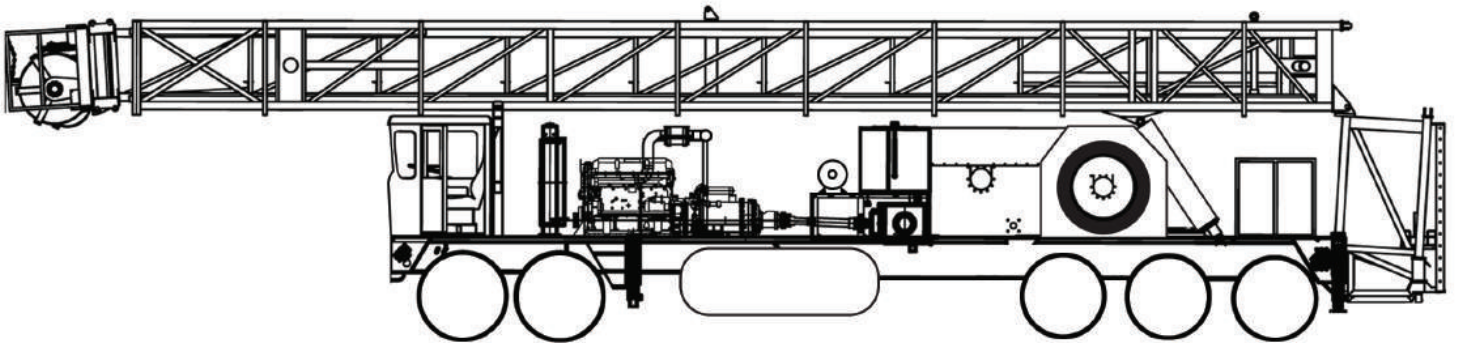



**FALCON
RIGS**



SR-550

Draw Works Model 550/42x12, 42x8

Main Drum

- Hardened overlaid demountable steel brake rims are 42in diameter x 12in wide. Drum shaft diameter is 6.5in. 1in wire line size standard.

Sand Line Drum

- Hardened overlaid demountable steel brake rims are 42in diameter x 8in wide
- Wire line capacity is 16,500ft of 9/16

Draw Works Features

- Water splash brake cooling
- Twin Kobelt 5026 48x7 disc assist brake
- 1in Lebus grooving on main drum
- 224 Wichita Clutch on sand line drum
- 324 Wichita Clutch on main drum

Mast Model 104/275

(Double Tubing, Triple Rods)-(per API 4F)

- 4-leg fixed base
- Clear height is 104ft below crown
- Static hook load capacity on 6 lines 219,000lbs
*8 lines 275,000lbs
- 30in fast line sheave
- 24in dead line sheave
- 24in sheave cluster
- All sheaves mounted on Timken double row bearings
- Racking platform capacity is 24,000ft of 2 7/8in tubing
- Hydraulic rams for raising and telescoping
- Adjustable work platform

OPTIONS

- Mast lighting
- Standpipes

OPTIONAL MAST MODELS

- 108/275
- 108/300

Drive Train

- Standard Detroit Diesel Series 60,500-540hp (Caterpillar or Cummins optional)
- Allison 4700 OFS 7-speed transmission (optional M5610A straight through or drop box 6-speed transmission)
- Cotta TR2205 transfer case with oil cooler
- Optional engine cover for weather protection

Carrier

- Standard 5-axle carrier
- Front axles (rated at 22,000lbs each) have spring suspension
- Rear axles (rated at 52,000lbs combined) have walking beam suspension
- Third (non-driving) rear axle with air bag lift suspension rated at 20,000lbs
- All axles monitored by a Bendix Anti-Lock Brake System

OPTIONS

- Fourth (non-driving) rear axle with air bag lift suspension rated at 20,000lbs
- Hydraulically raised operator's station

Controls and Hydraulic System

- Controls for all leveling jacks, mast raising and scoping cylinder, engine, transmission, main drum clutch, winch, and road to winch shifting are located in a stainless steel, clearly marked with laser etching, control box for quick, easy rig-up.
- 50gpm hydraulic pump for all rig hydraulics and tong operation
- Filters provided on suction and return lines
- Standard Braden PD12 Service Winch

Rig Options

- Hydraulic oil cooler for continuous use and hot climate applications
- Cold weather engine package with fuel, oil and coolant heaters
- Ventilated engine/transmission enclosure with removable doors
- Folding walkways on off-operator side
- Rotary drive package